













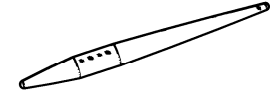

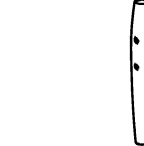





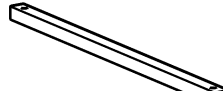

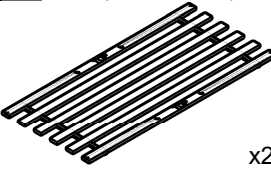





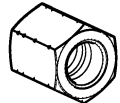
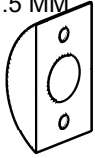

# ASSEMBLY INSTRUCTION

## SH2225K-1EK / SH2225BLKK-1EK

<b>1</b> Headboard Bottom Panel	<b>2</b> Headboard Top Rail	<b>3</b> Spindle W Screw Hole	<b>4</b> Spindle W/O Screw Hole	<b>5</b> Headboard Post
				
x1	x1	x6	x12	x2
<b>6</b> Headboard Connect Leg (L)	<b>7</b> Headboard Connect Leg (R)	<b>8</b> Footboard Leg	<b>9</b> Footboard Panel	<b>10</b> Front Side Rail (L)
				
x1	x1	x2	x1	x1
<b>11</b> Front Side Rail (R)	<b>12</b> Rear Side Rail (L)	<b>13</b> Rear Side Rail (R)	<b>14</b> Side Rail Support Leg	<b>15</b> Center Support Rail
				
x1	x1	x1	x2	x4
<b>16</b> Support Leg	<b>17</b> Slat (6 pcs / Roll)	<b>A</b> Screws M6 x 90mm	<b>B</b> Screws M6 x 50mm	<b>C</b> Screws M6 x 40mm
				
x8	x2	x4	x6	x8
<b>D</b> Screws M6 x 30mm	<b>E</b> Barrel Nut M6 x 13mm	<b>F</b> Wood Dowel 10 x 40mm	<b>G</b> Stud Bolt M6 x 60mm	<b>H</b> Hex Nut M6 (RB)
				
x2	x8	x8	x8	x8
<b>I</b> HalfMoon Washer Ø7.5 MM	<b>J</b> Spanner 10mm (M6)	<b>K</b> Allen Key M4 x 100mm	<b>L</b> CSK Screw M4 x 25mm	<b>M</b> PH Screw M4 x 45mm
				
x8	x1	x1	x8	x2
<b>N</b> PH Screw M4 x 38mm	<b>O</b> Flat Washer M6 x 19mm	<b>P</b> Flat Washer M6 x 13mm	<b>Q</b> Spring Washer M6 x 13mm	
				
x12	x8	x12	x8	

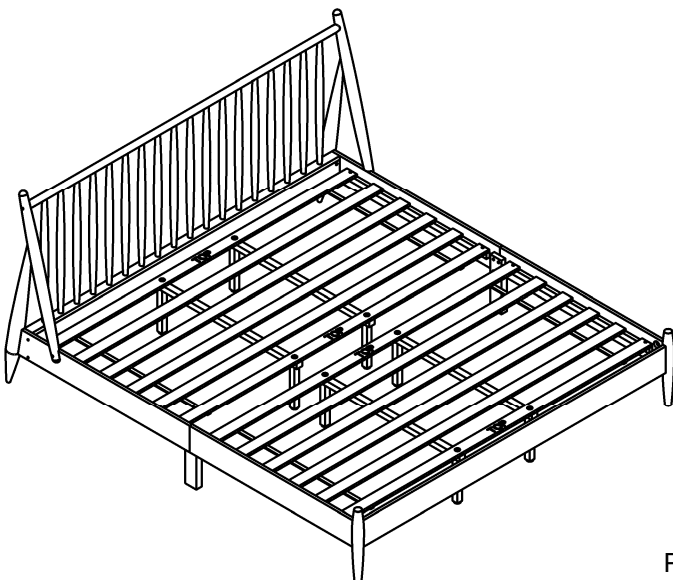

This page lists all contents included in the box. Please take the time to identify the hardware as well as the individual components to this product. As you unpack and prepare for assembly, place the contents on a carpeted or padded area to protect them from damage.

# ASSEMBLY INSTRUCTION

## SH2225K-1EK / SH2225BLKK-1EK

- 1** used plastic hammer insert all (3) and (4) into (1) and use (N) to tighten in (3)

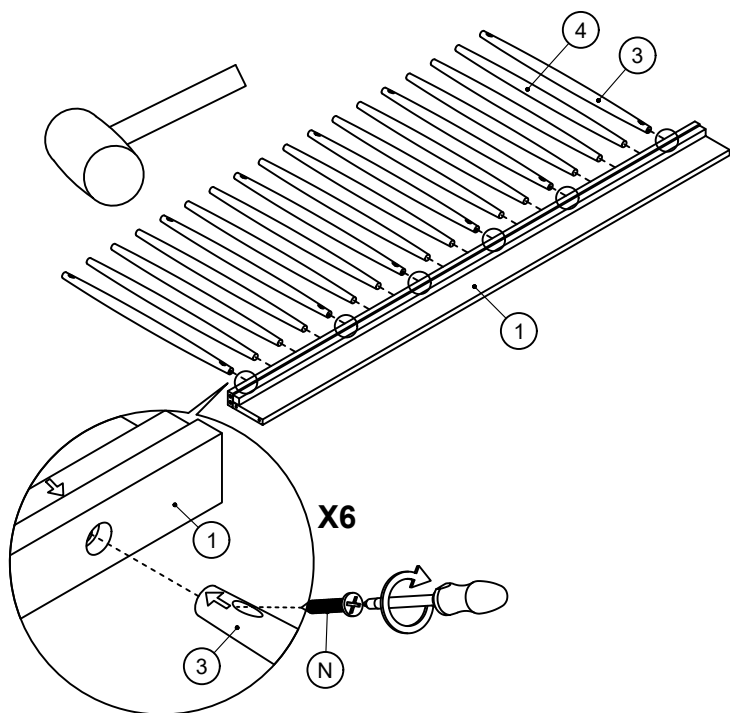

- 2** used plastic hammer insert 2 into (3) and (4) and use (N) to tighten in (3)

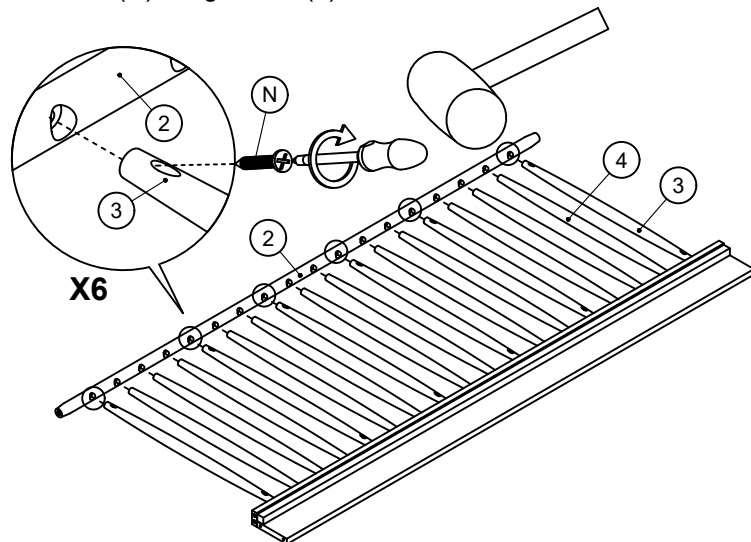

- 3** knock the Item(F) wood dowel into the (10)&(11)&(1) hole.

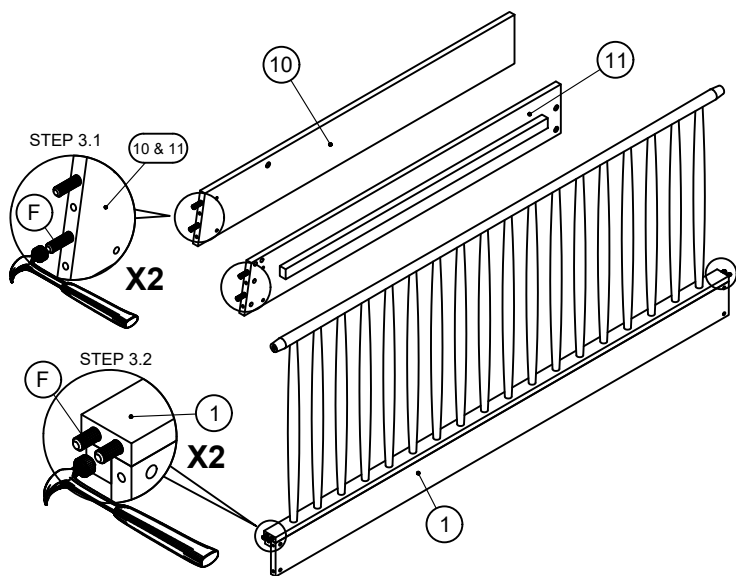

- 4** Insert (P) on (D) tighten them with (K) and Insert (P) on (A) tighten them with K in the relative positions according to the figure.

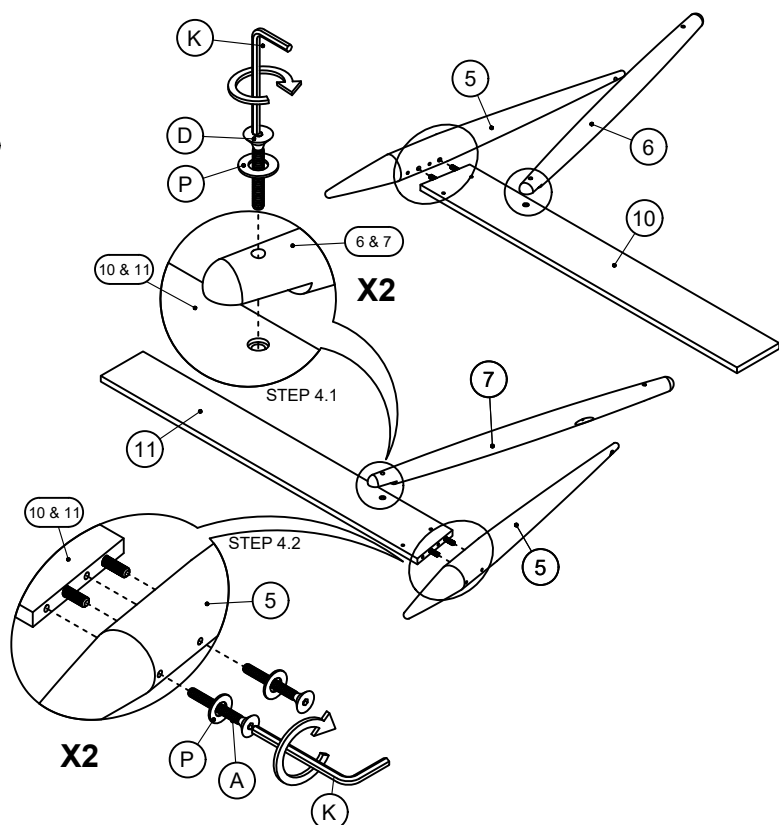

### Cleaning & Care

Treat surface with care. Surface is resistant to scratches but is not scratch resistant. Clean surfaces with a dry or damp soft cloth. Do not use abrasive cleaners. Hardware may loosen over time. Periodically check that all connections are tight. (DO NOT FULLY TIGHTEN ALL OF JCBC)

# ASSEMBLY INSTRUCTION

## SH2225K-1EK / SH2225BLKK-1EK

- 5** Insert (Q) AND (O) on (C) then tighten them with (K) the relative positions according to the figure.

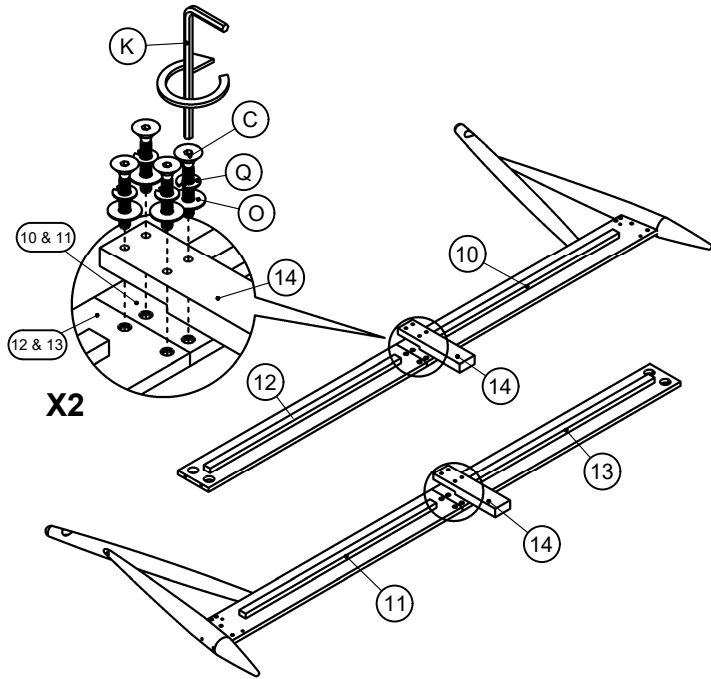

- 6** Insert (G) into (8) then insert (12) and (13) respectively into (G) that has just been connected to (8), then tighten (J) to (H) & (I)

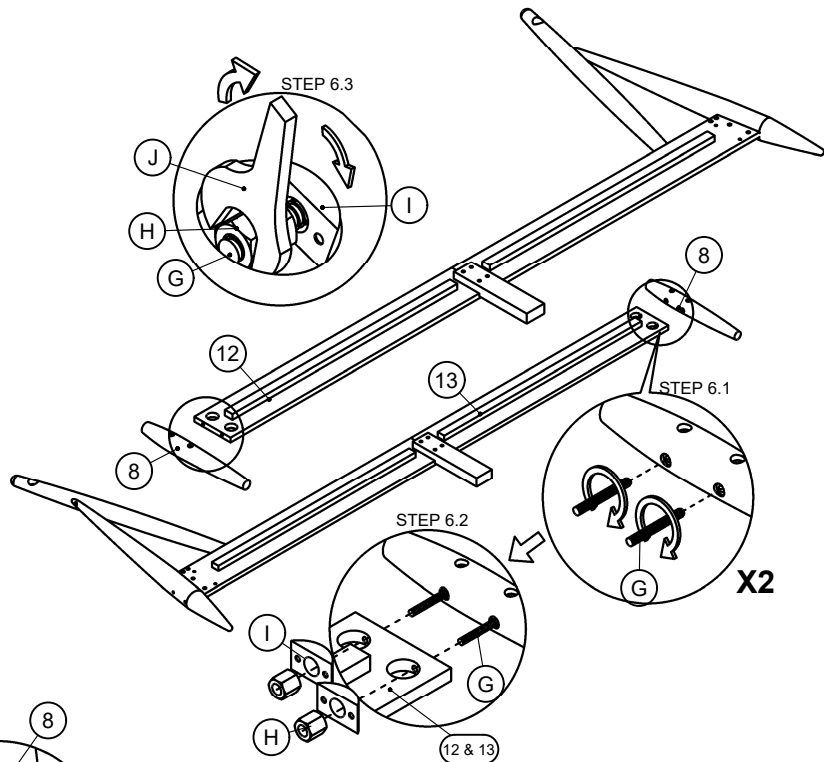

- 7** Insert (G) into (8) then insert (9) into (G) that has just been connected to (8), then tighten (J) to (H) & (I)

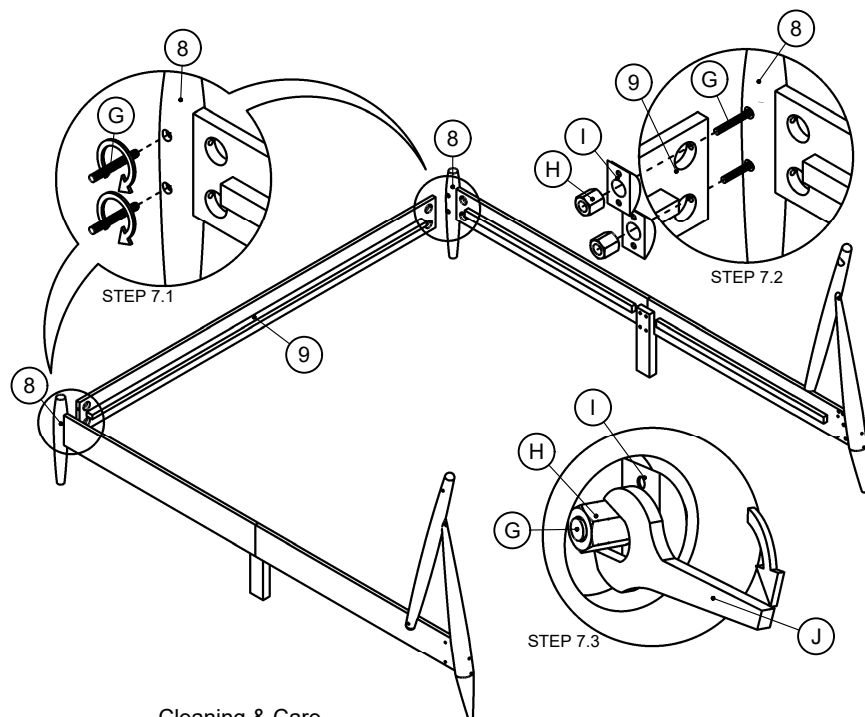

### Cleaning & Care

Treat surface with care. Surface is resistant to scratches but is not scratch resistant. Clean surfaces with a dry or damp soft cloth. Do not use abrasive cleaners. Hardware may loosen over time. Periodically check that all connections are tight. (DO NOT FULLY TIGHTEN ALL JCBC)

# ASSEMBLY INSTRUCTION

## SH2225K-1EK / SH2225BLKK-1EK

- 8** Insert (E) to (1) then insert (P) to (B) Then use (K) to tighten them relative positions according to the figure. used (M) tighten into (5)

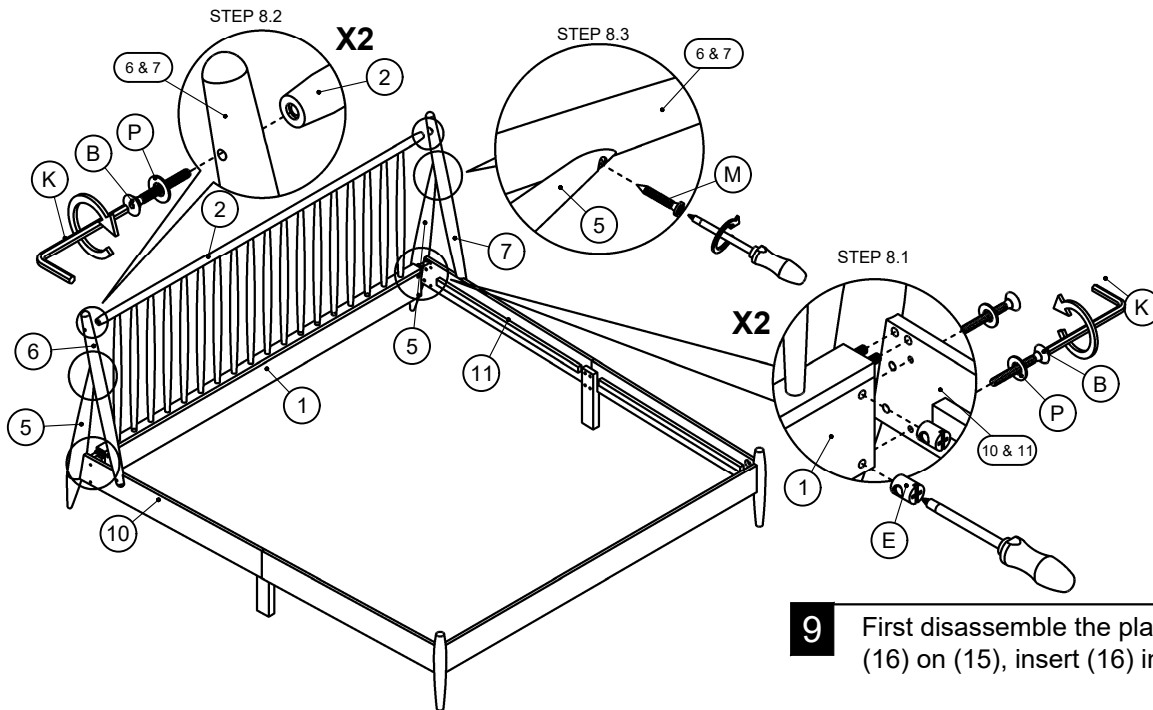

- 9** First disassemble the plastic on the hanger bolt, then install (16) on (15), insert (16) into (15) and (17) and tighten

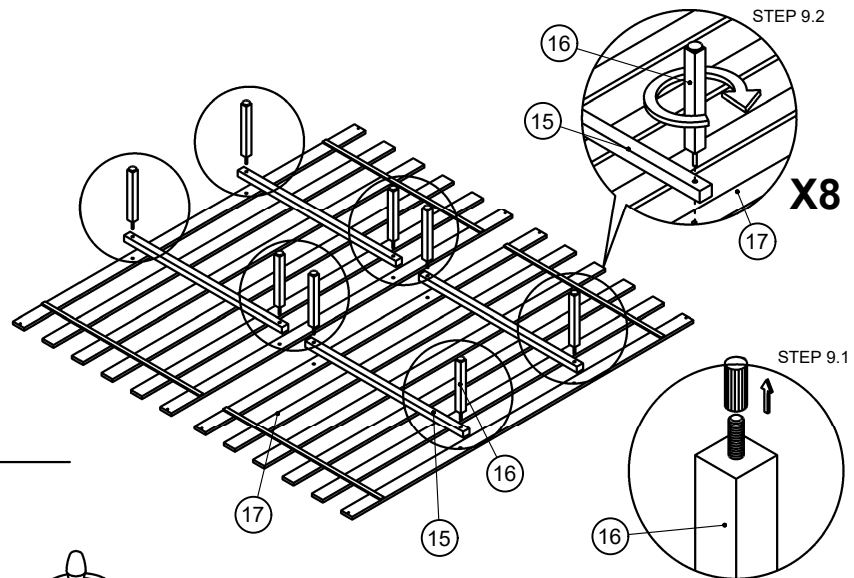

- 10** Turn (L) into the screw (17) using the Screwdriver then (Fully tighten all of screw and JCBC!!)

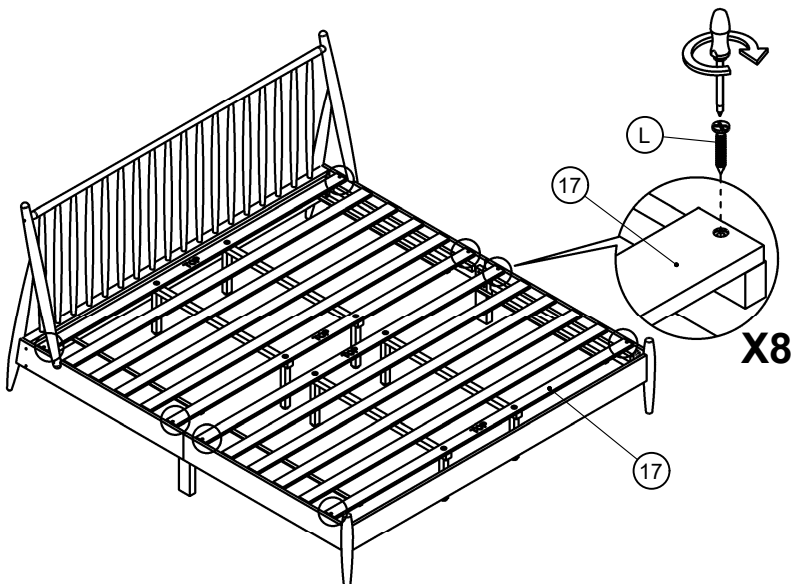

### Cleaning & Care

Treat surface with care. Surface is resistant to scratches but is not scratch resistant. Clean surfaces with a dry or damp soft cloth. Do not use abrasive cleaners. Hardware may loosen over time. Periodically check that all connections are tight.