





# ASSEMBLY INSTRUCTIONS

## GROUP NO: SH225BRN UPH QUEEN BED







Thank you for purchasing this product. Please take time to read and follow the instructions below. Check that you have all parts and hardware before assembly. Parts apparently missing are often found in the packing materials. If you do not have all the parts listed, have your dealer contact us and they be sent to you immediately.

 It is recommended to install protective pads under all legs and supports to avoid damage or scratches when placing furniture on a wood floor or other hard surface, and to limit indentation and prevent discoloration if placing on carpet.

### HARDWARE LIST FOR HEADBOARD:

No.	Description	Sketch	Size	Quantity
1	Allen Bolt		Ø5/16" x 45mmL	6 PCS
2	Spring washer		Ø5/16"	6 PCS
3	Flat washer		Ø5/16" x 19mm	6 PCS
4	Allen Key		4mm x 75mm	1 PC



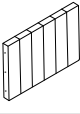
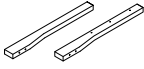

### HARDWARE LIST FOR SIDE RAIL & FOOTBOARD:

No.	Description	Sketch	Size	Quantity
5	Allen Bolt		Ø5/16" x 55mmL	4 PCS
6	Spring washer		Ø5/16"	4 PCS
7	Flat washer		Ø5/16" x 19mm	4 PCS
8	Allen Key		4mm x 75mm	1 PC
9	Screw		#8 x 30mmL	8 PCS
10	Hex Nut		Ø5/16"	8 PCS
11	Curve Washer		Ø5/16"	8 PCS
12	Thread Bolt		Ø5/16" x 80mmL	8 PCS
13	Open Wrench			1 PC

### PARTS LIST FOR HEADBOARD:

No.	Description	Sketch	Quantity
A	Headboard		1 PC
B	Headboard Post Leg - L&R		2 PCS

### PARTS LIST FOR SIDE RAIL & FOOTBOARD:

C	Footboard		1 PC
D	Side Rails		2 PCS
E	Slats		4 PCS
F	Support Legs		4 PCS
G	Footboard Leg		2 PCS

# ASSEMBLY INSTRUCTIONS

## GROUP NO: SH225BRN UPH QUEEN BED

### STEP 1 :

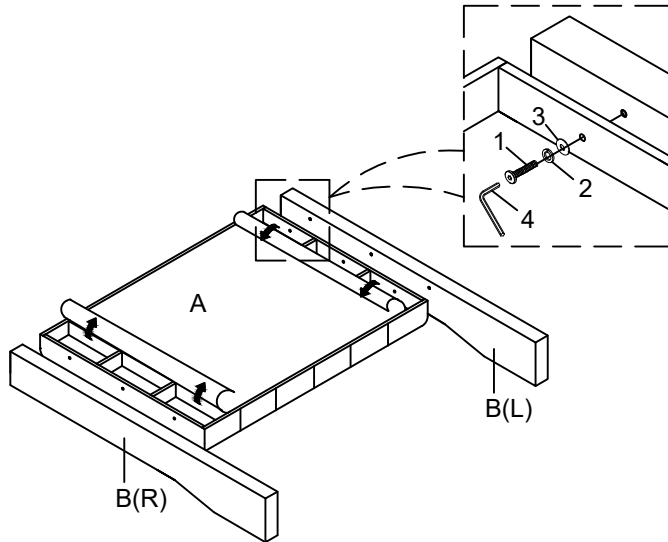

### STEP 2 :

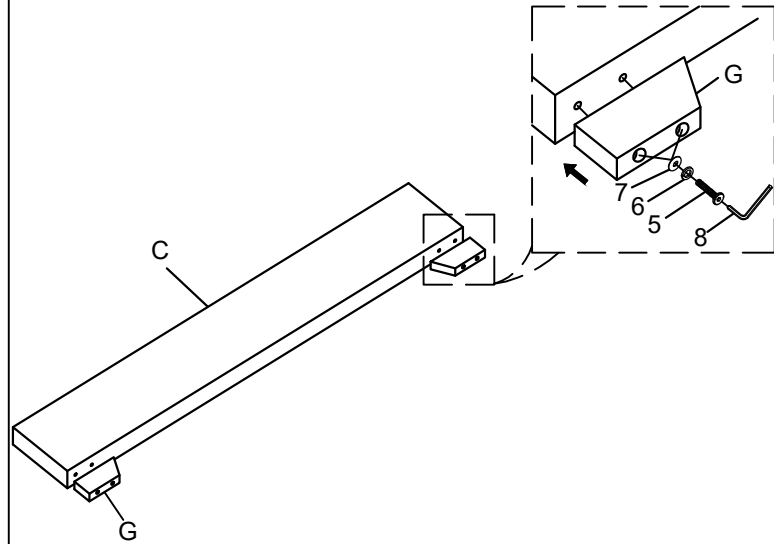

### STEP 3 :

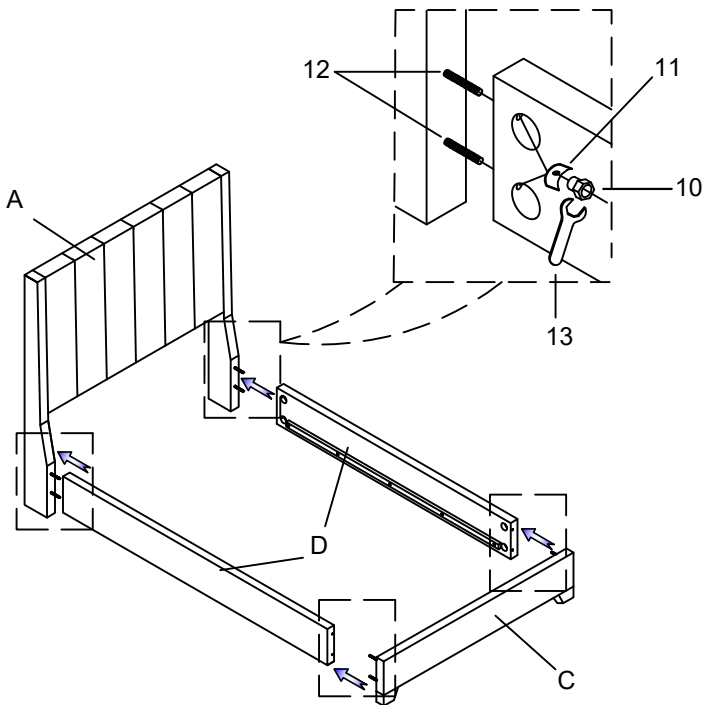

### STEP 4 :

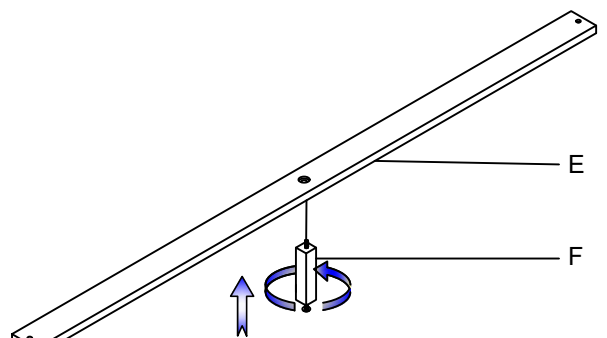

# ASSEMBLY INSTRUCTIONS

## GROUP NO: SH225BRN UPH QUEEN BED

### STEP 5 :

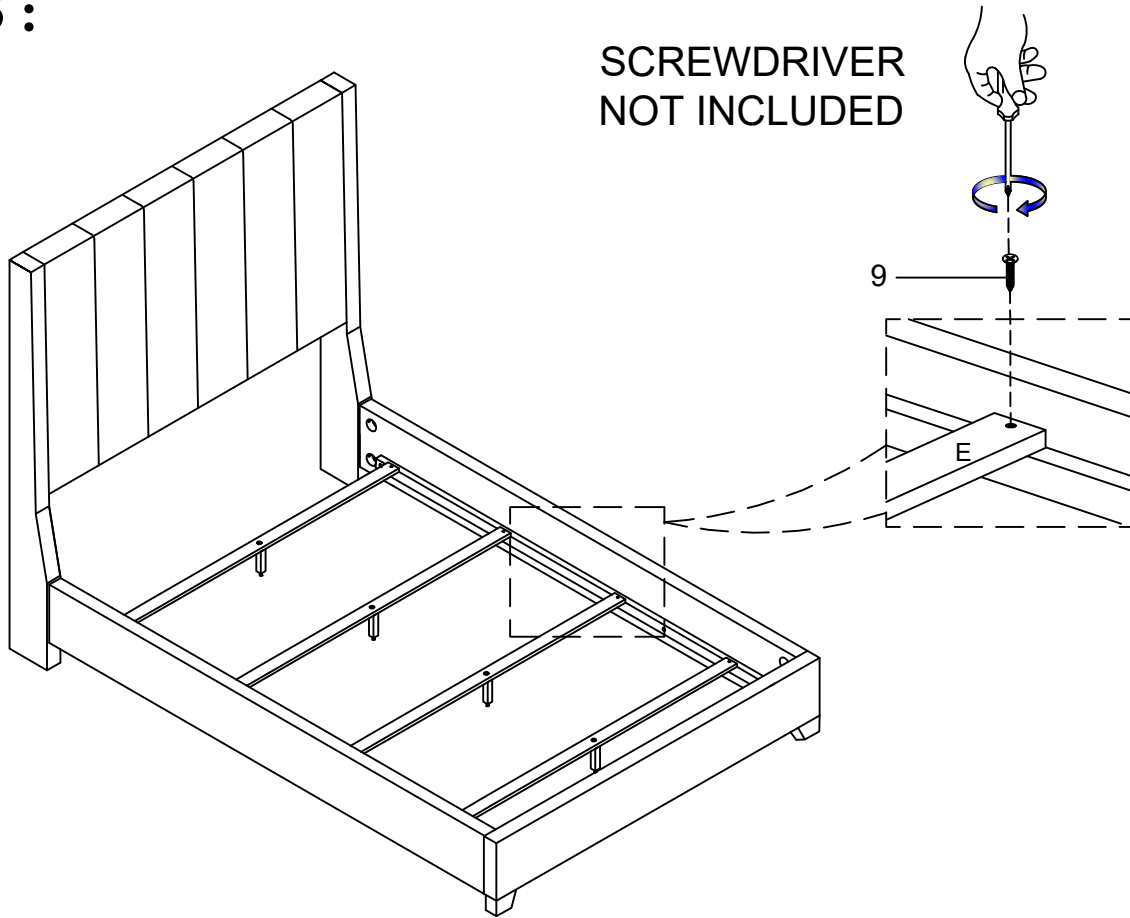

### Assembly Complete

