

# ASSEMBLY INSTRUCTIONS











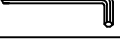

GROUP NO: SH228 - UPH EK BED



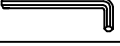

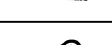

ITEM NO : SH228K-1 - Upholstered PU EK Headboard

SH228K-3 - Upholstered PU EK Footboard & Side Rail w/slats

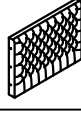
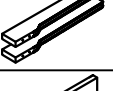
Thank you for purchasing this product. Please take time to read and follow the instructions below. Check that you have all parts and hardware before assembly. Parts apparently missing are often found in the packing materials. If you do not have all the parts listed, have your dealer contact us and they be sent to you immediately.

**▲** It is recommended to install protective pads under all legs and supports to avoid damage or scratches when placing furniture on a wood floor or other hard surface, and to limit indentation and prevent discoloration if placing on carpet.

| HARDWARE LIST FOR HEADBOARD:             |               |   |                |          |
|--|---------------|---|----------------|----------|
| No.                                      | Description   | Sketch  | Size           | Quantity |
| 1  | Allen Bolt    |    | Ø5/16" x 45mmL | 6 PCS    |
| 2  | Spring washer |    | Ø5/16"         | 6 PCS    |
| 3  | Flat washer   |    | Ø5/16" x 19mm  | 6 PCS    |
| 4  | Allen Key     |    | 4mm            | 1 PC     |
| HARDWARE LIST FOR SIDE RAIL & FOOTBOARD: |               |   |                |          |
| No.                                      | Description   | Sketch  | Size           | Quantity |
| 6  | Allen Bolt    |  | Ø5/16" x 45mmL | 2 PCS    |
| 7  | Spring washer |  | Ø5/16"         | 2 PCS    |
| 8  | Flat washer   |  | Ø5/16" x 19mm  | 2 PCS    |
| 9  | Allen Key     |  | 4mm            | 1 PC     |
| 10                                       | Screw         |  | #8 x 30mmL     | 16 PCS   |
| 11                                       | Hex Nut       |  | Ø5/16"         | 8 PCS    |
| 12                                       | Curve Washer  |  | Ø5/16"         | 8 PCS    |
| 13                                       | Thread Bolt   |  | Ø5/16" x 80mmL | 8 PCS    |
| 14                                       | Open Wrench   |  |                | 1 PC     |
| 15                                       | Wood Dowel    |  | Ø10 x 40mm     | 2 PCS    |

| PARTS LIST: |                 |   |          |
|-------------|-----------------|---|----------|
| No.         | Description     | Sketch  | Quantity |
| A           | Headboard       |    | 1 PC     |
| B           | Post (L/R)      |    | 2 PCS    |
| C           | Footboard       |    | 1 PC     |
| D           | Side Rail (L/R) |  | 2 PCS    |
| E           | Slats           |  | 4 PCS    |
| F           | Support Legs    |  | 8 PC     |
| G           | Bun Foot        |  | 2 PCS    |

# ASSEMBLY INSTRUCTIONS

GROUP NO: SH228 - UPH EK BED

ITEM NO : SH228K-1 - Upholstered PU EK Headboard

SH228K-3 - Upholstered PU EK Footboard & Side Rail w/slots

## STEP 1:

Attach the Posts (L/R) (B) to the Headboard (A) by using Allen Bolt (1), Spring Washer (2), Flat Washer (3) and Allen Key (4).

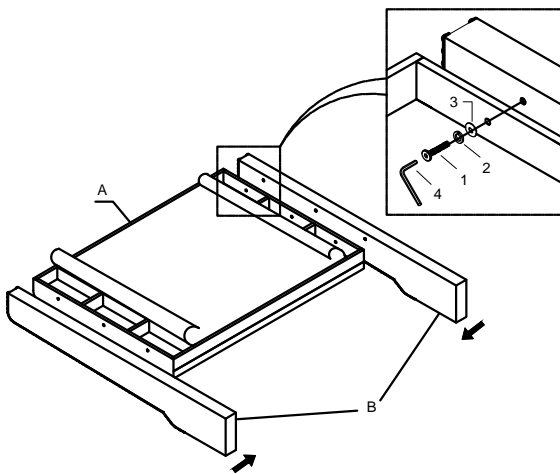

## STEP 2:

Attach the Bun Foot (G) to the Footboard (C) by using Allen Bolt (6), Spring Washer (7), Flat Washer (8), Wood Dowel (15) and Allen Key (9).

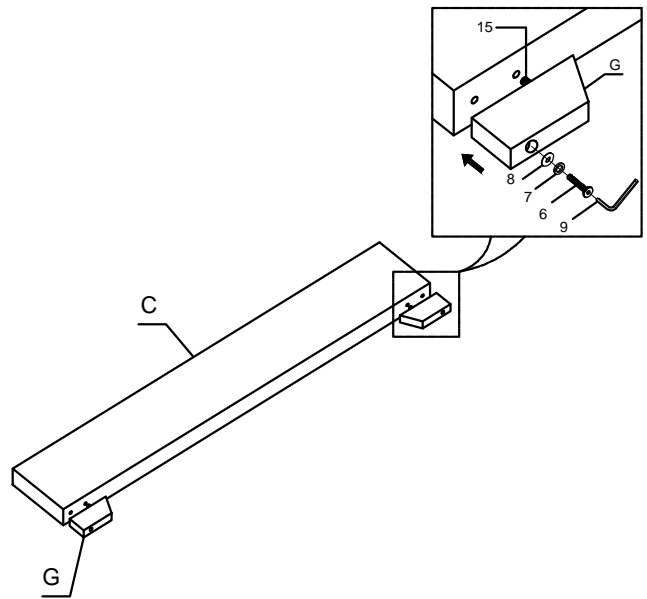

## STEP 3:

Attach the Side Rail (D) to the Headboard (A) and Footboard (C) by using Thread Bolt (13), Curve Washer (12), Hex Nut (11) and Open Wrench (14).

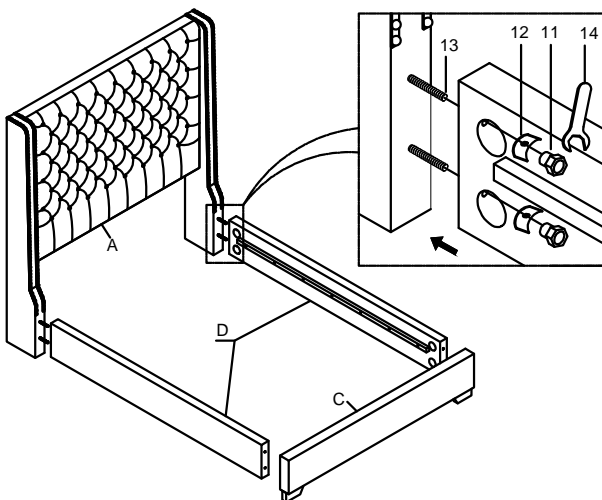

## STEP 4:

Attach the Support Legs (F) to the Slats (E).

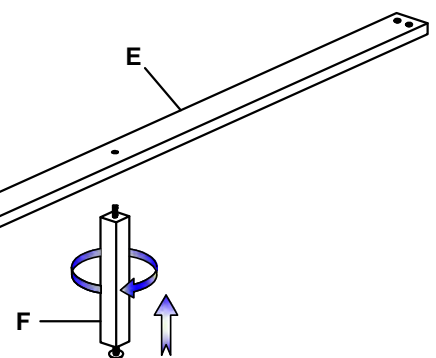

# ASSEMBLY INSTRUCTIONS

GROUP NO: SH228 - UPH EK BED

ITEM NO : SH228K-1 - Upholstered PU EK Headboard

SH228K-3 - Upholstered PU EK Footboard & Side Rail w/slats

## STEP 4:

Attach the Slats (E) to the Side Rail (D) by using Screw (10).

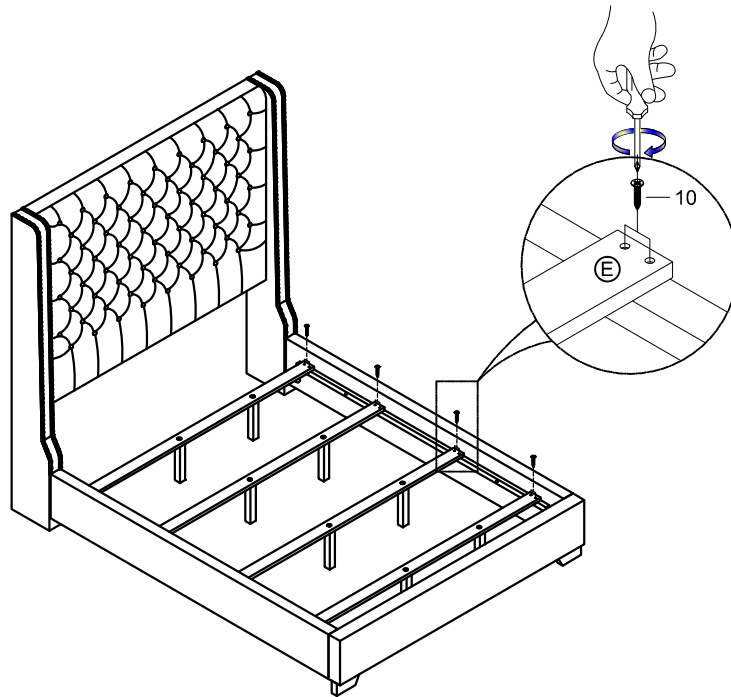

Assembly Complete

