

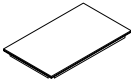

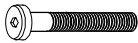

# ASSEMBLY INSTRUCTION

ITEM NO: SH1187-36: 7-PIECES PACK COUNTER HEIGHT SET

Thank you for purchasing this quality product. Be sure to check all packing material carefully for small parts that may have come loose inside the carton during shipment.

PARTS / TABLE				HARDWARE LIST / TABLE				
NO	Description	Sketch	Q'ty	NO	Description	Sketch	Size	Q'ty
A	Table Top		1PC	1	Long Bolt		Ø5/16" x 75mm	8PCS
B	Table leg		4PCS	2	Lock Washer		Ø5/16"x13Dx2mm	8PCS
				3	Flat Washer		Ø5/16"x19D x 2mm	8PCS
				4	Allen Key		4mm	1PC

Step 1

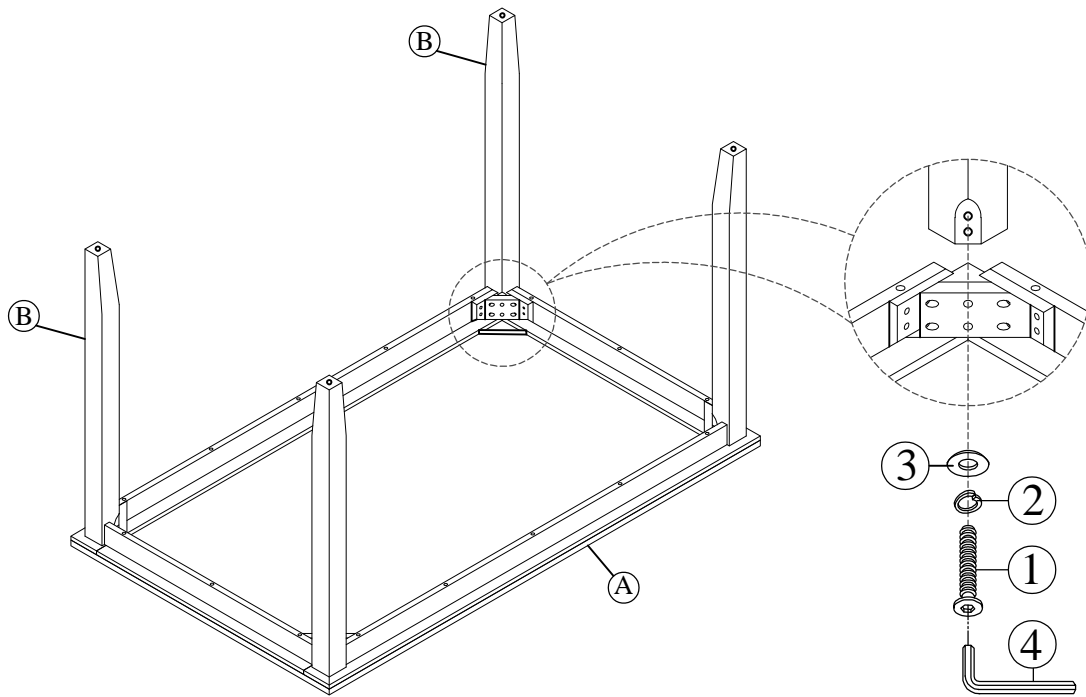



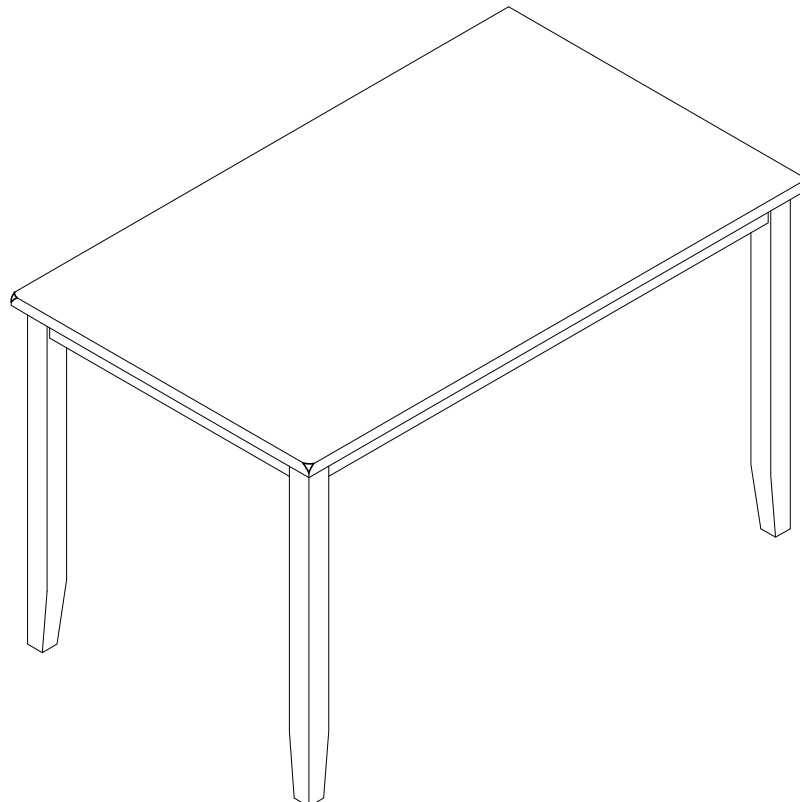







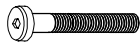

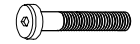

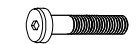
Completed



# ASSEMBLY INSTRUCTION

## ITEM NO: SH1187-36: 7-PIECES PACK COUNTER HEIGHT SET

Thank you for purchasing this quality product. Be sure to check all packing material carefully for small parts that may have come loose inside the carton during shipment.

PARTS / CHAIR				HARDWARE LIST / CHAIR				
NO	Description	Sketch	Q'ty	NO	Description	Sketch	Size	Q'ty
A	Chair Back		1PC	1	Long Bolt		Ø1/4" x 75mm	4PCS
B	Seat Frame		1PC	2	Medium Bolt		Ø1/4" x 60mm	4PCS
C	Seat Cushion		1PC	3	Short Bolt		Ø1/4" x 40mm	2PCS
D	RSF Front Leg		1PC	4	Lock Washer		Ø1/4"x13Dx2mm	10PCS
E	LSF Front Leg		1PC	5	Flat Washer		Ø1/4"x19D x 2mm	10PCS
F	RSF Stretcher		1PC	6	Allen Key		4mm	1PC
G	LSF Stretcher		1PC	7	Screws		#4"x38mm	12PCS
H	Front Stretcher		1PC					

### Step 1

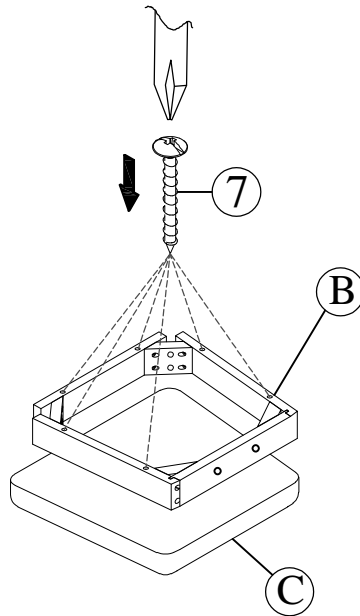

### Step 2

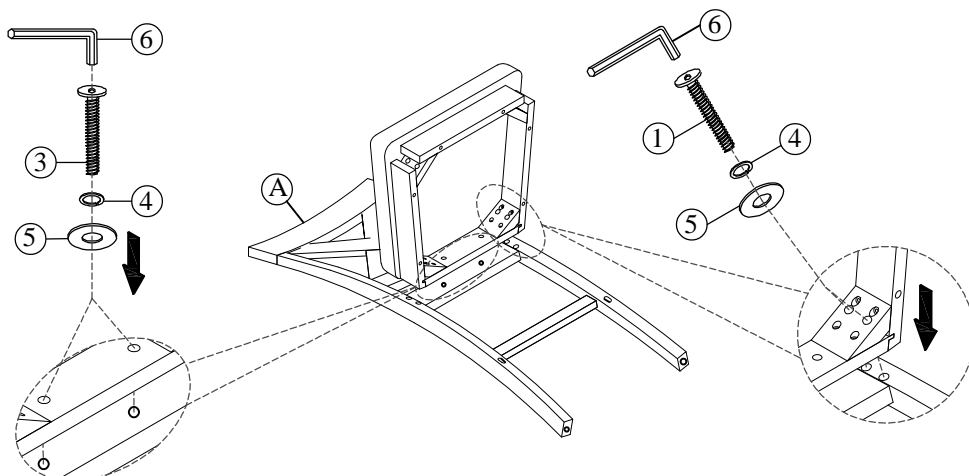

ASSEMBLY INSTRUCTION  
ITEM NO: SH1187-36: 7-PIECES PACK COUNTER HEIGHT SET

Step 3

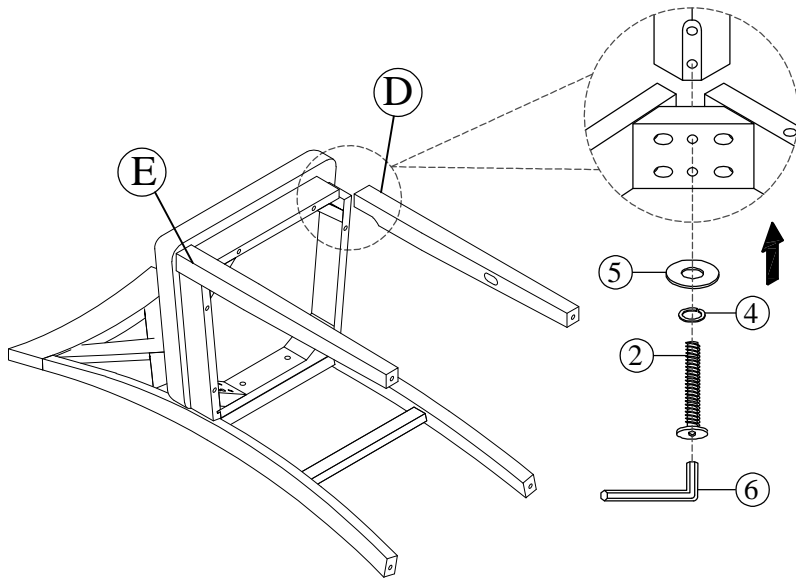

Step 4

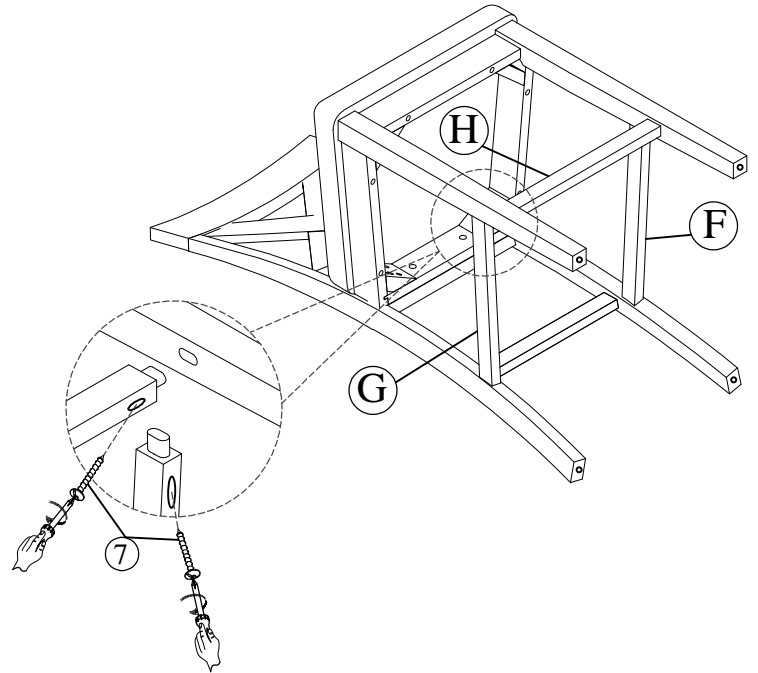

Completed

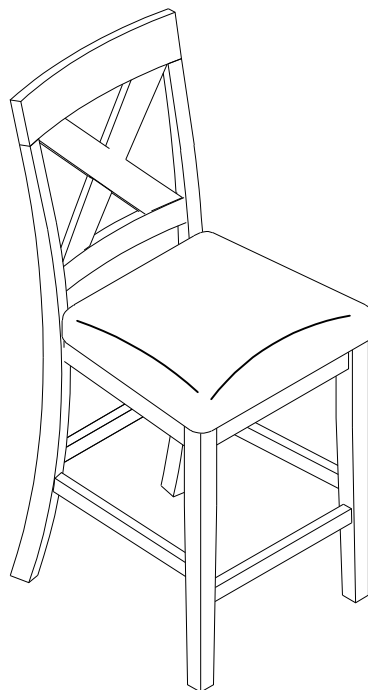

HARDWARE MAY LOOSEN OVER TIME. PERIODICALLY CHECK TO MAKE SURE ALL CONNECTIONS ARE TIGHT.  
DO NOT TIGHTEN BOLTS UNTIL COMPLETELY ASSEMBLED.  
RE-TIGHTEN IF NECESSARY.



It is recommended to install protective pads under all legs and supports to avoid damage or scratches when placing furniture on a wood floor or other hard surface, and to limit indentation and prevent discoloration if placing on carpet.